

Annual Report

2022

BOOSTING VOTER TURNOUT

FULL SLATE PROJECT

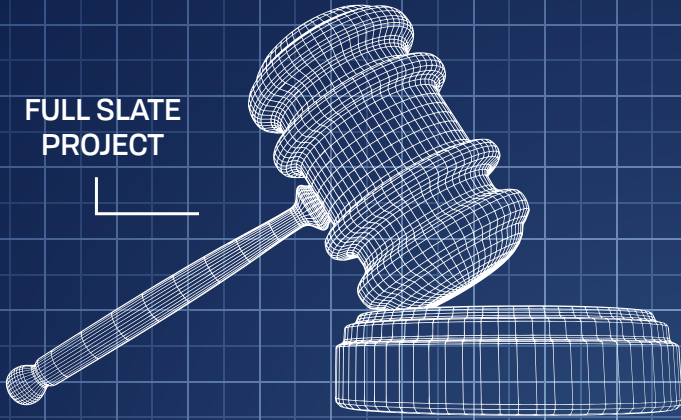

UNMASKING THE "WORKERS' RIGHTS AMENDMENT"



AMENDMENT 1

BUILDING FREE-MARKET INFRASTRUCTURE

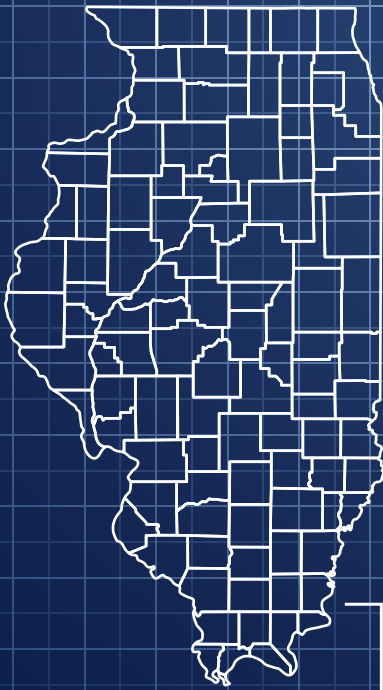

ILLINOIS
POLICY
INSTITUTE

ILLINOIS
POLICY

FIGHTING ENTRENCHED UNION POWER

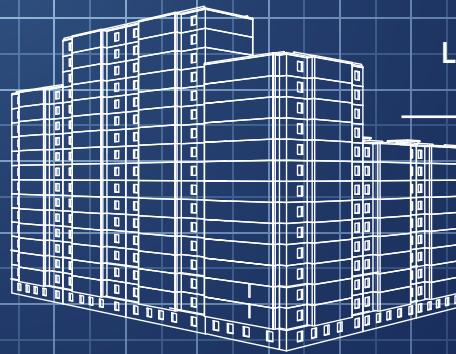

LOCAL 1

EXPOSING A "FAKE BREAK"

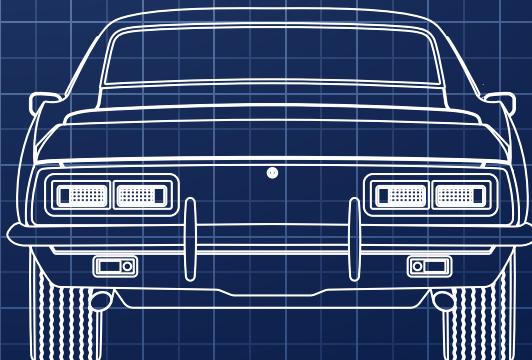

GAS TAX

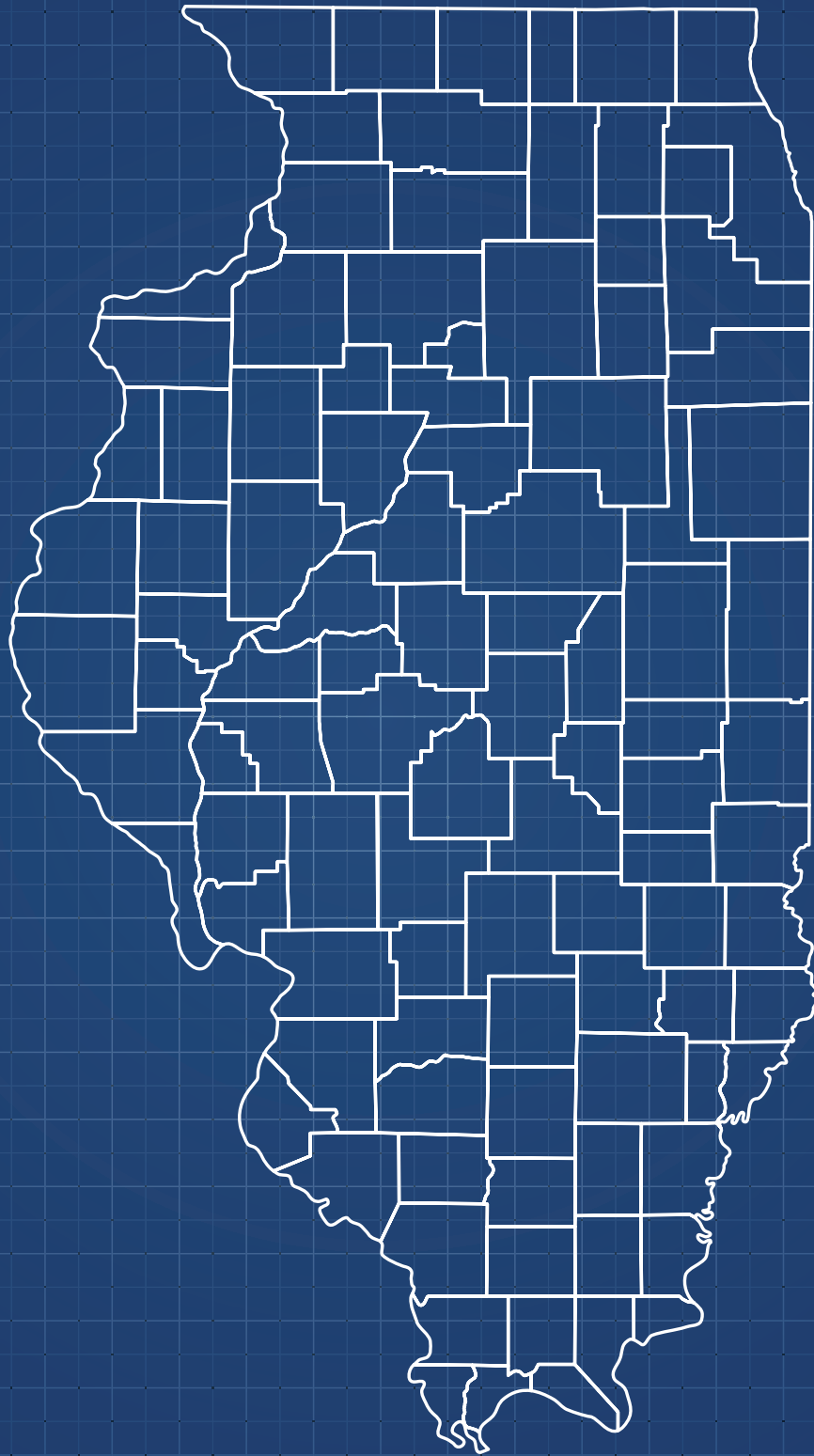

TABLE OF CONTENTS

06	—————	A YEAR IN REVIEW A letter from Matt Paprocki
08	—————	BOOSTING VOTER TURNOUT
10	—	UNMASKING THE "WORKERS' RIGHTS AMENDMENT"
12	—————	FIGHTING ENTRENCHED UNION POWER
14	—————	EXPOSING A "FAKE BREAK"
15	—————	BUILDING FREE-MARKET INFRASTRUCTURE
17	—————	GUEST SPEAKER SERIES
18	—————	FINANCIALS
19	—————	THE ILLINOIS POLICY INSTITUTE TEAM

WHO WE ARE

The Illinois Policy Institute is the strongest voice for taxpayers in the state. We stand up for regular Illinoisans who deserve a voice in their government, but have been ignored in favor of special interests for too long.



We educate and engage Illinoisans from all walks of life to ensure our state is a place where everyone has the opportunity to thrive. Illinois is a place we should all be proud to call home.

The Illinois Policy Institute is a nonpartisan 501(c)(3) research organization. Our partner organization, Illinois Policy, is an independent, nonpartisan 501(c)(4) advocacy organization.

THE ILLINOIS POLICY INSTITUTE BELIEVES

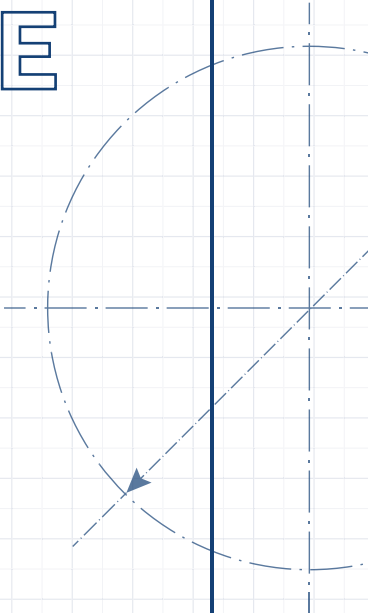
- 
- That civil and personal liberties must be protected and preserved.
 - Illinois should be a place where people of all talents, interests and cultural backgrounds can succeed with hard work and ingenuity.
 - In effective, efficient, honest and transparent government that is accountable to taxpayers and residents in need, not political special interests.
 - That the best policies empower people – and limit the power of government.
 - That a public pension system that threatens to bankrupt our state, drive down economic growth and evaporate retirements for public-sector workers is immoral – but that modest reforms can solve this crisis.
 - Property taxes must be brought under control so people are not forced out of their homes.
 - Workers deserve the right to choose whether a labor union serves their values and interests.
 - Economic policy should focus on creating jobs and opportunities for all.
 - Voters deserve choices at the ballot box and no politician is entitled to a “safe” seat.
 - Each child should have access to educational opportunities that prepare them for the future.

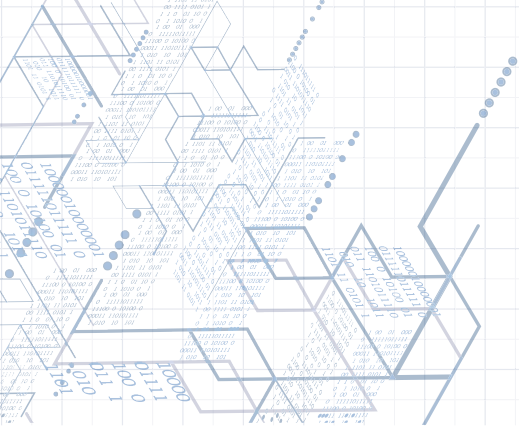

A YEAR IN REVIEW

A letter from Matt Paprocki

IT'S TIME TO reflect on a year of building the critical infrastructure to restore Illinois' freedom and prosperity. We are grateful to you, our investors and partners, who believe in our commonsense mission and have been leading the fight to transform our state. It's your generosity that makes everything we do possible.

We saw in 2022 an opportunity to rectify a problem Illinois has faced for far too long: uncontested elections. With millions of voters living in districts with only one candidate on the ballot, they had no incentive to get out and vote. And they found themselves stuck with one-party representation.

We were determined to boost voter turnout and give free-market voters a voice in democracy, so you helped us recruit and train a total of 34 candidates to run against incumbents in historically uncontested districts.

As a result of our Full Slate Project, the 2022 ballot saw the greatest number of contested elections in 30 years. For the first time in the 17 years I've lived in Chicago, I had a choice between candidates for state representative and candidates for state senator on my ballot.

Ultimately, 262,000 more voters cast ballots for free-market candidates. They would not have had such an opportunity without this initiative.

Traditionally, candidates who did not face challengers would transfer over \$8.5 million per year

to the top suburban races in the state. Because of the Full Slate Project, that practice ended in 2022.

Your support helped us train these candidates on free-market principles, secure voter choice for underrepresented Illinoisans and disrupt the standard flow of machine politics.

And we're just getting started.

I'm inspired by the energy and enthusiasm I saw in these grassroots candidates. Ed Kornegay decided to run against Illinois House Speaker Chris Welch in the 7th District after his son was shot in the head while getting groceries. Thankfully, his son survived.

While he did not win on his first attempt, Kornegay is committed to working hard every day these next two years to enact change in the 7th District. He's already pledged a rematch against Speaker Welch in 2024. His perseverance reminds me of Abraham Lincoln, who put his feet in the right place and stood firm, never backing down until accomplishing what he set out to do.

This is the kind of spirit that will lead to Illinois' renewal.

Boosting voter turnout in 2022 was particularly important in our campaign to unmask the union-backed "Workers' Rights Amendment" – and inform voters about what exactly it meant before heading to the polls.

We all remember seeing the feel-good ads for the “Workers’ Rights Amendment” during Bears games, but while the unions spent \$16 million pushing their propaganda, we were busy researching the actual amendment and alerting voters to the fact that it would increase their property taxes. Four out of the five biggest Chicago newspapers – and The Wall Street Journal – took up our cause to expose this big labor takeover and recommend a “no” vote.

Amendment 1 barely limped across the finish line. Now we must stand guard and hold the unions accountable. We’ll ensure union power can’t make life in Illinois unaffordable for people like Phalese Binion, who had to pay \$14,000 on her first property tax bill for a \$98,000 house in Park Forest. That’s astronomical and unacceptable.

And despite unions passing Amendment 1, individual union members are exercising freedom and are leaving the unions in record numbers. In 2022 alone, your investment helped the Illinois Policy Institute process over 17,000 union members opting out of their government union. Now, union funding is being reduced by \$38 million every year – to its lowest level ever.

One of our biggest projects from 2022 is to educate people about the effects of uncontrolled union power. It is our new, feature-length documentary: “Local 1: The Rise of America’s Most Powerful Teachers Union.”

This film shows the impact the Chicago Teachers Union has had not only on our government, but on the lives and futures of children. We’re fighting for the right of every family to choose where to send their kids to school – and providing hope for a brighter future.

We’re building the momentum to make lasting changes in our state, and you’ve been a guiding light through its many fiscal problems. Your contribution is making Illinois’ comeback possible.

Thank you for having faith in Illinois and in our mission to make this a place we are all proud to call home.

In liberty,



MATTHEW T. PAPROCKI
President and CEO

**WE’RE BUILDING THE
MOMENTUM TO MAKE
LASTING CHANGES IN OUR
STATE, AND YOU’VE BEEN A
GUIDING LIGHT THROUGH ITS
MANY FISCAL PROBLEMS.**

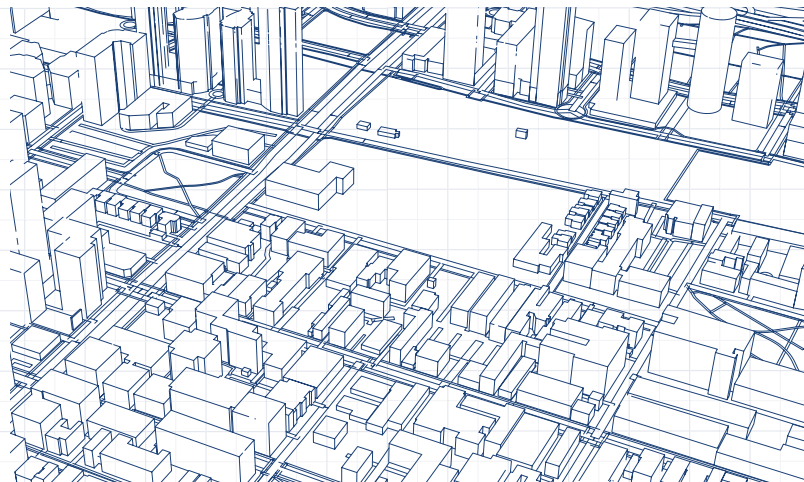

BOOSTING VOTER TURNOUT

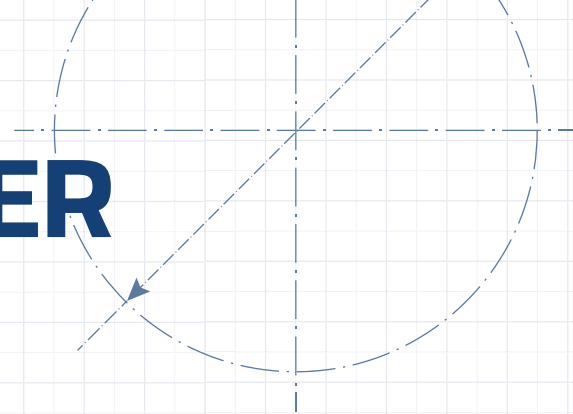

“In my district, our rep has been holding this seat for almost 16 years without any contest. So, he would always get 100% of the votes. That’s not real voter freedom, because voters have no choice.”

-ALPER TURAN

Republican candidate for Illinois House District 13

THE GREATEST ENEMY Illinois faces is not the Chicago Teachers Union, the Democratic Party or Socialism – it’s apathy. We’re not giving up on Illinois, and voters need to know they have the power to make a difference, even in a solidly blue state.

We launched major initiatives last year to get more pro-free market voters to the polls.

Critical to boosting voter turnout was registering as many people as possible to vote by mail. We identified over 1 million voters who were aligned but not likely to vote, and we convinced 211,780 of them to register to vote by mail at a cost of \$0.77 per conversion.

But for many Illinoisans, the issue was not whether they should vote – the issue was they had no choice to make.

In the past decade, 49% of all Illinois House of Representatives races, on average, were uncontested. There were 4.7 million Illinois voters in districts in which there was only one candidate on the ballot. That means millions of voters were not able to participate in democracy because there was no choice and no one had been running to represent their values.

A lack of voter choice is a form of voter suppression. That is why we launched our Full Slate Project – an effort to recruit and train pro-free market candidates to run in historically uncontested districts.

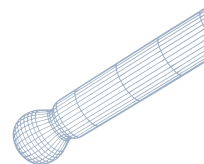

MILLIONS OF VOTERS WERE NOT ABLE TO PARTICIPATE IN DEMOCRACY BECAUSE THERE WAS NO CHOICE AND NO ONE HAD BEEN RUNNING TO REPRESENT THEIR VALUES.

A total of 34 aligned candidates challenged Democratic incumbents in both the state House and Senate. Ten of these candidates were endorsed by the Chicago Tribune. At one point, 112 of Illinois' 118 House districts had a GOP candidate.

Our goal was for each of these candidates to receive 20% or more of the vote. As it turned out, they regularly outperformed that goal. The Full Slate Project boosted voter turnout by 262,000.

For example, in Chicago, Christine McGovern received 47.1% of the vote for Illinois Senate. For state representative, Mark Albers got 35.6% of the vote; Matthew Schultz got 34.4%; and David Sheppard got 38.7%.

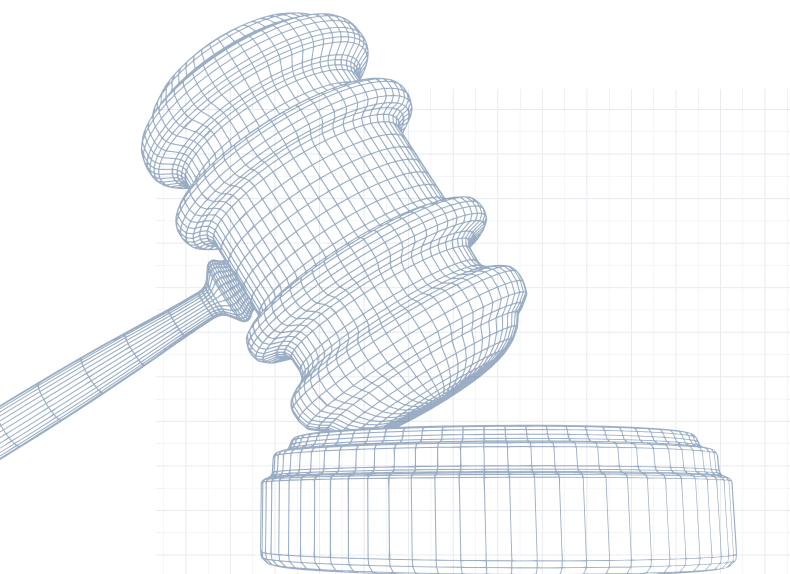

This is a huge achievement because if you're a conservative and get 20% of the vote in Chicago, you would win a statewide contest.

Additionally, Full Slate Project candidates forced the opposition's party to spend \$8.5 million on these contested races rather than on the top-tier, competitive races. This was strategically important because it prevented Democratic incumbents from securing easy victories.

What we found out with the Full Slate Project was 20% isn't the ceiling – it's the floor.

A LACK OF VOTER CHOICE IS A FORM OF VOTER SUPPRESSION. THAT IS WHY WE LAUNCHED OUR FULL SLATE PROJECT – AN EFFORT TO RECRUIT AND TRAIN PRO-FREE MARKET CANDIDATES TO RUN IN HISTORICALLY UNCONTESTED DISTRICTS.

We're just getting started on our initiative to provide voters with a full slate of candidates. We'll be building on this effort in future elections.

Enough Illinoisans resonate with our common-sense message to turn this state around. We just need to continue empowering them and providing them with choices on their ballots.

UNMASKING THE “WORKERS’ RIGHTS AMENDMENT”

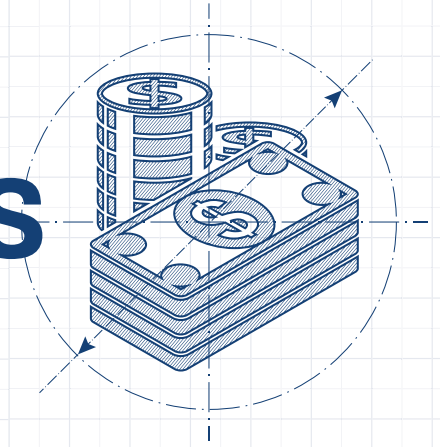

THERE WAS A trojan horse on the ballot in November, and although it may have been snuck into the city, we’re not going to flee or accept defeat. We’re going to stay and fight.

Amendment 1 was a scheme to permanently cement collective bargaining power in the Illinois Constitution. Government unions promoted it as the “Workers’ Rights Amendment” without mentioning it could apply at most to only 7% of Illinois workers. The National Labor Relations Act already protects collective bargaining rights for private sector workers, so this amendment can only apply to government employees.

Illinois Policy Institute research shows the amendment could lock in property tax hikes for the median home in Illinois by approximately \$2,149 during the next four years – and that’s a conservative estimate. With government union power protected by our constitution, union leaders could seize the opportunity to make radical demands during their collective bargaining agreements. This could drive up the cost of government and make taxpayers a main source of revenue.

When the spokesperson for the Vote Yes for Workers’ Rights campaign was asked by WGN if Amendment 1 would raise property taxes, he

Amendment 1 guarantees \$2,149 property tax hike for typical Illinois family

Increase in projected average property bill relative to 2022

Year	Increase
2023	\$207
2024	\$422
2025	\$645
2026	\$876
4-year total	\$2,149

Uses compound annual growth rates in home prices as reported by the All-Transactions House Price Index for Illinois from 2010-2021 to project future average home values through 2026. Uses compounded annual growth rate in average property taxes as calculated by U.S. Census Bureau for 2010-2019 to project property taxes through 2025.

Source: U.S. Census Bureau, U.S. Federal Housing Finance Agency @illinoispolicy

said, “We don’t have a crystal ball, so there’s no way for anyone to predict what these negotiations are going to look like.”

That told us everything we needed to know.

We were determined to unmask the amendment and inform voters this was not about workers’ rights, but yet another ploy to raise their taxes.



Our extensive marketing campaign achieved the following:

- 20 million video views on digital and streaming platforms
- 21 million display ad impressions on websites such as espn.com and weather.com
- 7 million text messages sent to voters
- 3 million unique engagements on Meta alone

Because of you, we were able to drive the narrative, influence voters and nearly defeat the amendment. The Wall Street Journal, the Chicago Tribune, Crain's Chicago Business, the Daily

Herald and the News-Gazette took up our cause and recommended Illinois voters reject a big labor takeover.

Our late-September polling showed that only 29% of voters would vote "no" on Amendment 1. But the election results had the "no" vote at 41.3% – over a 12-point increase. We kept the "yes" vote below the 60% of votes on the question required to win outright. Instead, the question needed to win a majority of all the ballots cast in the election. Under this measure, Amendment 1 passed by only 106,000 votes out of 4.1 million cast.

Amendment 1 passed not because of its merits, but because of its deceptions. The unions outspent us by 5:1, yet we still came so close to defeating the amendment. Your support helped us share our free-market vision with top media and change the hearts and minds of many voters. You made this a tight race rather than a blowout for the unions.

Despite this setback, our fight against Amendment 1 is not over. We will continue to review its effects and analyze possible litigation routes.



FIGHTING ENTRENCHED UNION POWER

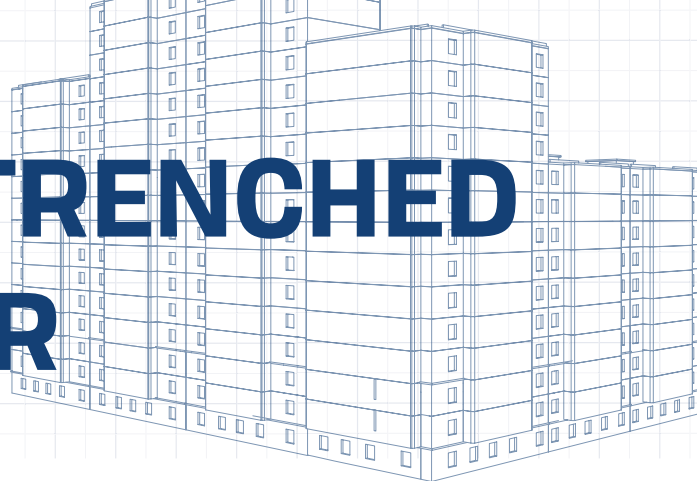

UNIONS HAVE HISTORICALLY existed to secure better wages, benefits and working conditions for the working class. They were committed to representing workers' interests and fighting for their rights.

But as unions have become more powerful, they have increasingly become political machines advancing a radical ideology. Union bosses enrich themselves and worker representation is only a secondary consideration.

Benny Durbin is a public works specialist in the town of Arthur, Illinois, who opted out of his union, saying, "I just didn't feel well-represented, or like there was enough support from our union. They didn't really help us when we went into negotiations. They never really asked us what we wanted."

To put things in perspective, only 20% of AFSCME Council 31's spending is on worker representation. The same is true of the Chicago Teachers Union: just 19% of their spending is on representation.

This is why so many union members like Benny are leaving their unions.

But they didn't always have this fundamental right.

For decades, government union workers were required to financially support their unions as a condition of employment. This unconstitution-

al scheme changed in 2018 when our litigation partner, the Liberty Justice Center, represented child support specialist Mark Janus in court.

We helped Mark argue that forcing him to subsidize his union was a violation of his First Amendment right to free speech. The case was appealed all the way up to the U.S. Supreme Court, which sided with Mark.

Mark and workers throughout America won a pivotal victory in the fight for workers' rights.

After the landmark Janus decision, we launched a multiyear campaign to educate Illinois public sector workers about their constitutional right to cease dues payments to their unions. This is necessary because workers were being unfairly exploited by an unconstitutional fee requirement – and many are still paying dues without knowledge of their right to work without paying a fee to do so.

In 2022, we continued our effort to inform union workers of their rights by sending informational mailers to their homes, which contained opt-out letters to their unions and employers. This is the most cost-effective strategy to help people opt out of their union.

Now, when a union such as the CTU goes on strike, we immediately receive hundreds of opt-out forms. People like Benny Durbin finally have a choice.

Because of your investment, union funding continues to be reduced by \$38 million every year. In 2022, union membership in Illinois declined by 17,000, according to the U.S. Bureau of Labor sta-

tistics. This is part of a 33-year downward trend, which saw union membership drop to 13.1% in 2022 from 20.8% in 1989.

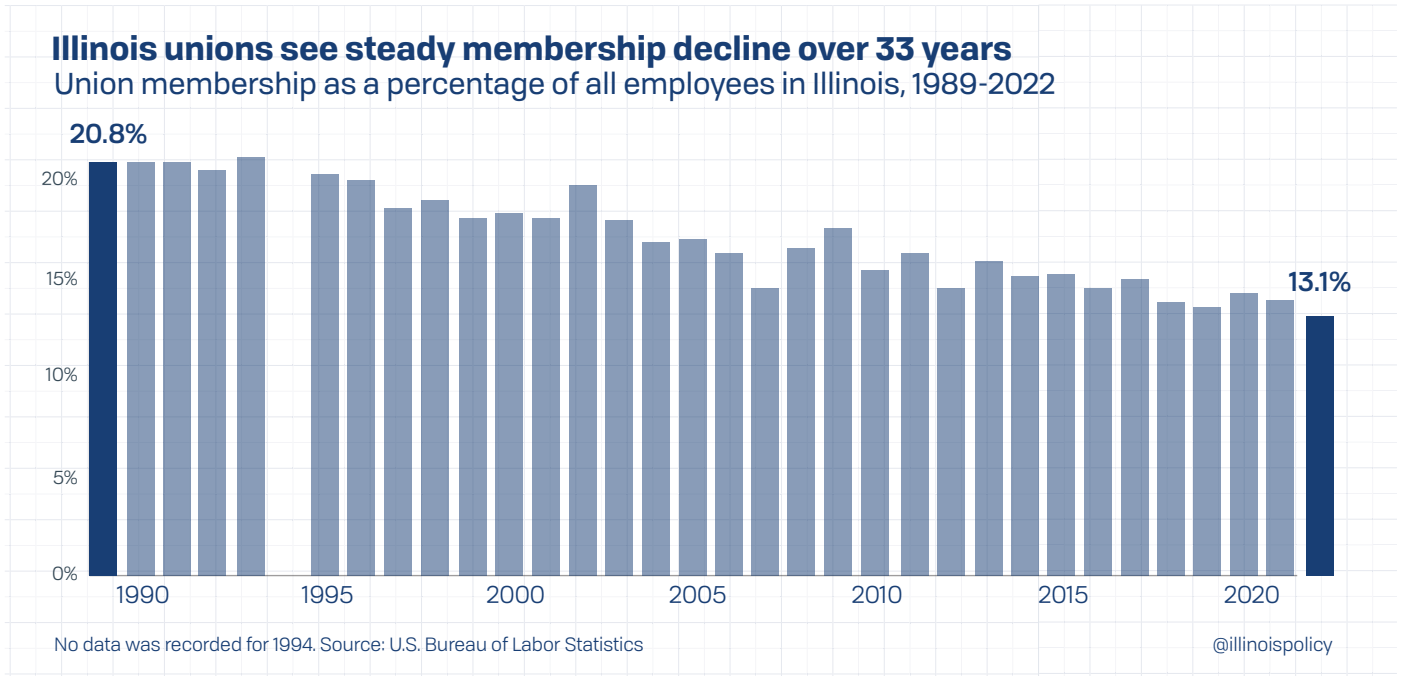

Picture a sold-out concert at All-State Arena: that’s how many union members opted out just last year.

Since 2017, over 38,000 government workers have opted out of membership, including almost 10% of public school educators. Unions’ ability to influence elected officials through government contracts has been greatly diminished.

This is so important because CTU has been attempting to thwart better educational opportunities for Chicago’s gifted students trapped in underperforming schools. But the good news is Gov. J.B. Pritzker reversed his stance on the Invest in Kids Act, which enables low-income students to attend a private or charter school of their choice.

In 2022, we produced an eye-opening documentary film exposing the Chicago Teachers’ Union

and its impact on not only students and families in Chicago, but also public policy across our state and nation. “Local 1: The Rise of America’s Most Powerful Teachers Union” is now available to stream for free at chicagoteachersunion.com, or on our YouTube channel.

Its message that there is a better way than union militancy should help even more Illinois workers exercise their freedom of choice in 2023.

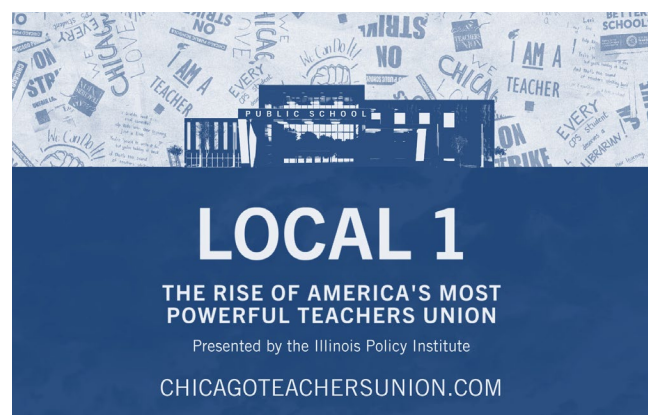

EXPOSING A “FAKE BREAK”

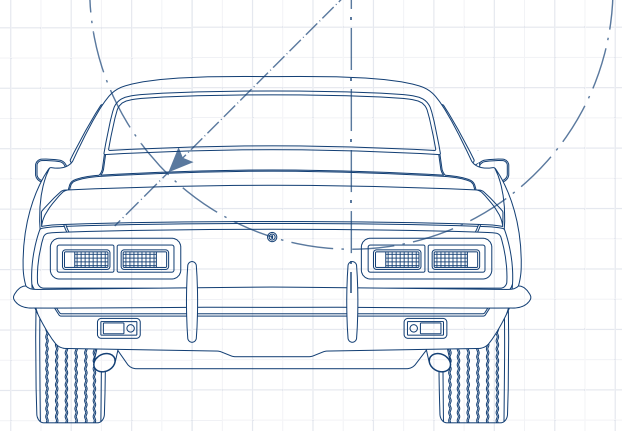

ILLINOIS LAWMAKERS HANDED taxpayers a “fake break” last summer when they postponed the state’s annual, automatic gas tax increase to 2023 and suspended Illinois’ 1% grocery tax for one year.

Politicians hawked their actions as temporary “relief” measures that would ease taxpayers’ burden during a time of rampant inflation. In truth, the election season stunt imposed two gas tax increases on Illinoisans in 2023 and did not eliminate the grocery tax, which only 12 other states impose on their residents’ need to eat.

Lawmakers then forced gas station and grocery-store owners to post signs at their businesses that advertised the temporary “relief” through election season. Gas station owners who did not comply faced a fine of \$500 a day.

Your investment helped us counter the propaganda with creativity and quick action. We partnered with the Illinois Fuel & Retail Association

to create signs that could be distributed to their 300 retail members who control roughly 5,000 gas stations across the state. This is about 95% of all gas stations. The signs included a QR code that customers could scan to see how much of their gas purchases went to taxes.

Illinoisans used our gas tax calculator around 50,000 times to see just how much Pritzker’s tax hike was costing them. Our sign was even featured on Tucker Carlson Tonight, with 3 million nightly viewers. During the segment, nearly 200 people scanned the QR code as it appeared on the screen.

Tucker Carlson’s response to our campaign: “I love this so much.”

Together, we exposed this campaign season “fake break” and informed taxpayers that lawmakers were not giving them true relief.

J.B. PRITZKER HAS HIKE GAS TAXES EVERY YEAR SINCE 2019.

Illinois now has the **SECOND-HIGHEST** gas taxes in the nation. Pritzker has delayed the next gas tax hike until **AFTER THE ELECTION**. And he's forcing us to tell you about it with this sign, or pay a **\$500/DAY FINE**.

See how much Illinois politicians are costing you with our **GAS TAX CALCULATOR**.

As of July 1, 2022, the State of Illinois has suspended the inflation adjustment to the motor fuel tax through December 31, 2022. The price on this pump should reflect the suspension of the tax increase.

GAS STATION OWNERS STRIKE BACK
|| TUCKER CARLSON TONIGHT ||

ILLINOIS POLITICIANS HAVE MORE THAN DOUBLED THE GAS TAX SINCE 2019.

Illinois now has the **highest** gas taxes in the Midwest. And the **second-highest** in the nation. This year, lawmakers decided to delay their gas tax hike until **AFTER THE ELECTION**. And they are forcing us to tell you about it with this sign, or pay a **\$500/day fine**.

See how much Illinois politicians are costing you with our **GAS TAX CALCULATOR**.

Illin.Is/GasTaxCalc

As of July 1, 2022, the State of Illinois has suspended the inflation adjustment to the motor fuel tax through December 31, 2022. The price on this pump should reflect the suspension of the tax increase.

BUILDING FREE-MARKET INFRASTRUCTURE



THE ILLINOIS POLICY Institute continues to grow in reach and impact, spreading our commonsense free-market message to a wider audience every year.

Earned audience members become part of our community by sharing their first names, last names, email addresses and ZIP codes. These opt-ins reduce the cost of delivering our message to the right audience at the right time, especially in critical election years such as 2022.

Engaged audience size, 2014-2022

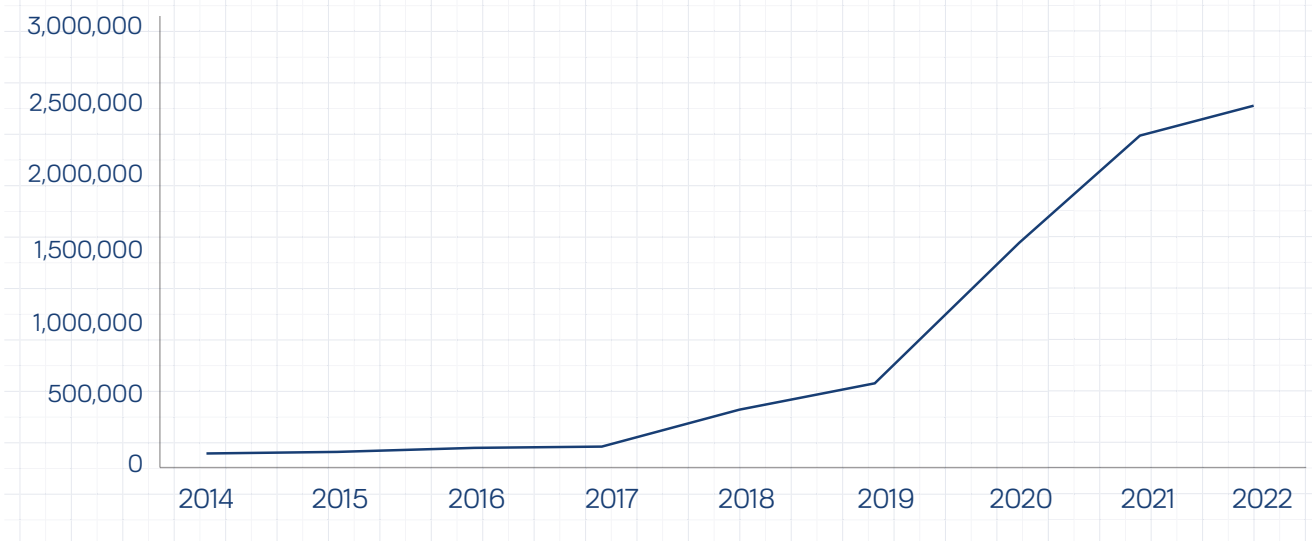

In 2020, our earned audience was 1.5 million. By the next election year, that number increased by 1 million, with an earned audience of 2.5 million at the end of 2022.

Additionally, 2.7 million viewers clocked over 9 million views on illinoispolicy.org last year. On all social media platforms, our content received 41.7 million impressions and 4.9 million engagements.

Outlet	Followers
Facebook	366k
Twitter	38k
Instagram	9k
Youtube	8k

The number of our op-eds that have been published in major newspapers continues to grow every year, with 41 op-eds published just last

year in targeted newspapers. This was a new record for the Illinois Policy Institute, beating out our top competitors.

Published opinion pieces grew from 2018 to 2022

Opinion pieces published in target outlets Chicago Tribune, Chicago Sun-Times, Crain's Chicago Business, Daily Herald, National Review, RealClear and Wall Street Journal.

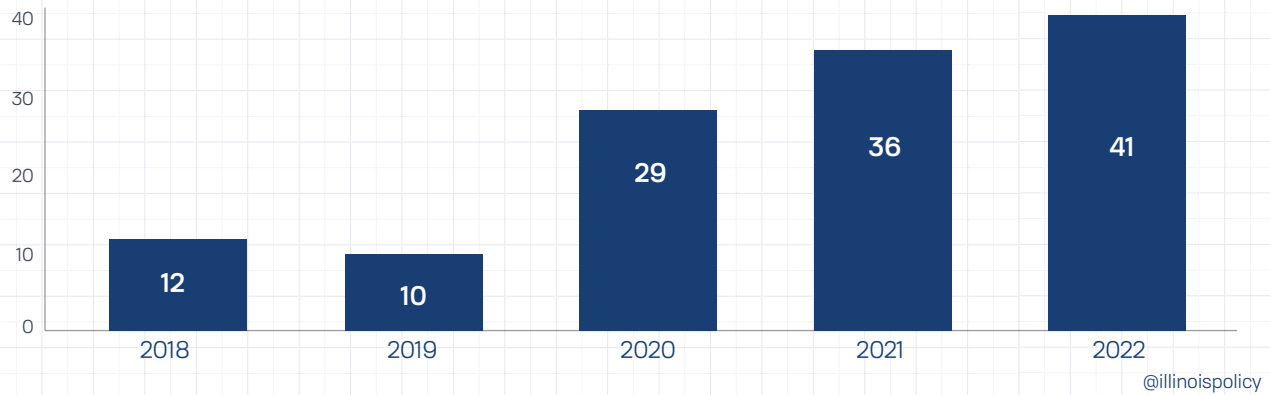

Op-eds published in target outlets

Op-eds published in Chicago Tribune, Chicago Sun-Times, Crain's Chicago Business, Daily Herald, National Review, RealClear and Wall Street Journal in 2022.

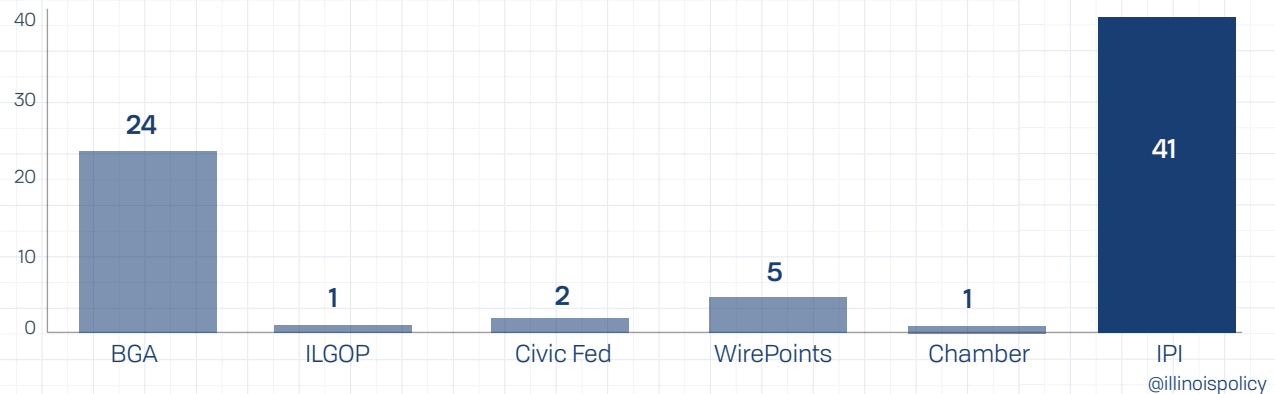

We also published 60 Your Story profiles on our website, telling the story of policy through everyday Illinoisans' experiences. Serving as the strongest advocate for taxpayers means giving underrepresented Illinoisans a voice and an opportunity to share how they've struggled under the status quo.

Your investment has helped us grow into an influential free-market think tank that is making life better for Illinoisans. With your continued support, we can further expand our reach and lead Illinois' comeback.

GUEST SPEAKER SERIES

IN 2022, THE Illinois Policy Institute hosted a guest speaker series featuring influential free-market voices from national media, nonprofits and government. Thank you to all those who attended these events at the University Club of Chicago and participated in the discussion. Special thanks to our guest speakers for traveling to Illinois to share their ideas about how to transform our state.



Virginia Lt. Gov. Winsome Sears, alongside Gov. Glenn Youngkin, won a major upset victory over Democratic incumbent Gov. Terry McAuliffe in November 2021. She joined us on Aug. 18 and discussed what can happen in a blue state when conservative voters engage fully and energetically in the democratic process.



Ian Rowe is a senior fellow at the American Enterprise Institute, where he focuses on education and upward mobility, family formation and adoption. He is the co-founder of Vertex Partnership Academies, a network of international baccalaureate high schools in the Bronx. Ian spoke to us on Sept. 29 about school choice and how disadvantaged kids can develop agency and rise to success.



Jonah Goldberg was named by Atlantic Magazine as one of the top 50 political commentators in the United States. He's a columnist at the Los Angeles Times and a fellow at both the National Review Institute and the American Enterprise Institute. He joined us on Dec. 8 and shared his ideas about the success of the free market in alleviating global poverty.

The guest speaker series increases the diversity of thought in our state. Watch for the next opportunity to attend a stimulating evening that celebrates liberty.

FINANCIALS

ILLINOIS POLICY INSTITUTE

REVENUE

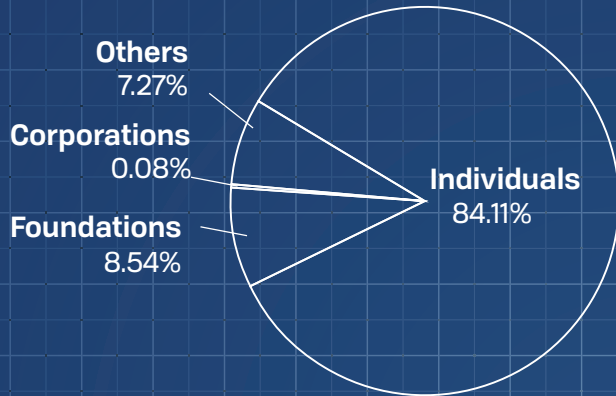

Total: \$5,477,222

EXPENSES

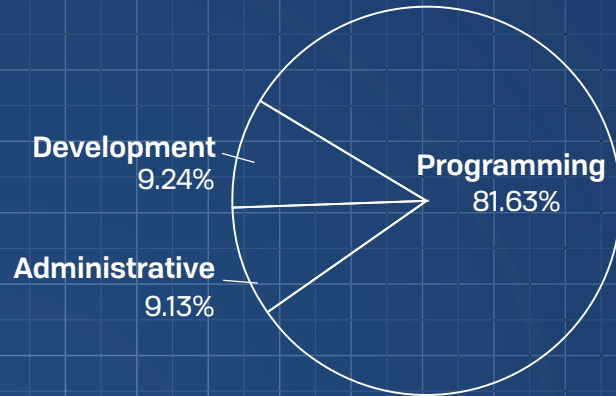

Total: \$7,782,533

ILLINOIS POLICY

REVENUE

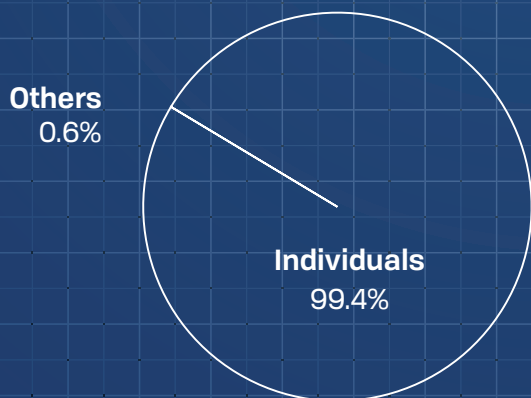

Total: \$5,563,272

EXPENSES

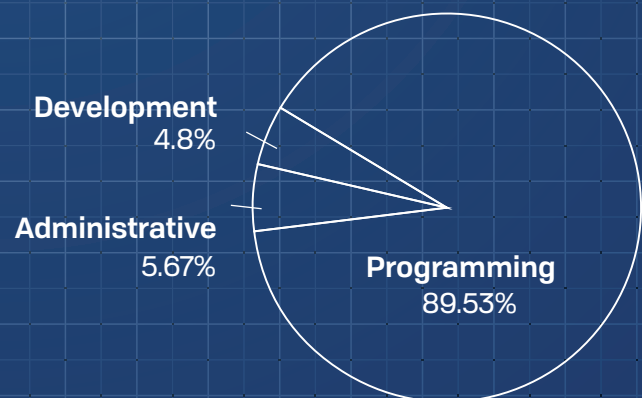

Total: \$5,969,983

THE BOARD

John Tillman
Chairman

Mark Miller
Secretary

Sherry Street
Director

Ed Bachrach
Vice Chairman

Sara Albrecht
Director

Dick Weiss
Director

Art Margulis
Treasurer

Craig Manske
Director

Matt Paprocki
President

Andy Gowdy
External Relations Officer

Amy Korte
Executive Vice President

Aidan Grogan
Development Writer

Hilary Gowins
Senior Vice President

Bryce Hill
Director of Fiscal and Economic
Research

Chris Andriesen
Vice President of Operations

Micky Horstman
Media Relations Intern

Austin Berg
Vice President of Marketing

Robert Isham
External Relations Officer

Jim Long
Vice President of Government Affairs

Katherine Condon
External Relations Officer

Eric Allie
Editorial Cartoonist

Melanie Krakauer
Director of Communications

Patrick Andriesen
Writer

Hannah Max
Policy Analyst

Justin Carlson
Policy Analyst

Vincent Caruso
Community Manager

Dan Patlak
Director of Advocacy

Jessica Plowman
Video Storyteller

Haneen Razzouk
Special Assistant to the President

Jordan Ryan
Senior Director of Government Affairs

Jordan Schneider
Executive Assistant

Gabriella Shanahan
Executive Assistant

Dylan Sharkey
Assistant Editor

Mailee Smith
Senior Director of Labor Policy and
Staff Attorney

Rebecca Susmarski
Communications Associate

Joe Tabor
Senior Policy Analyst

Zack Urevig
Director of Development Operations

Brad Weisenstein
Managing Editor

Perry Zhao
Policy Intern

THE TEAM



ILLINOISPOLICY.ORG
Follow us @illinoispolicy

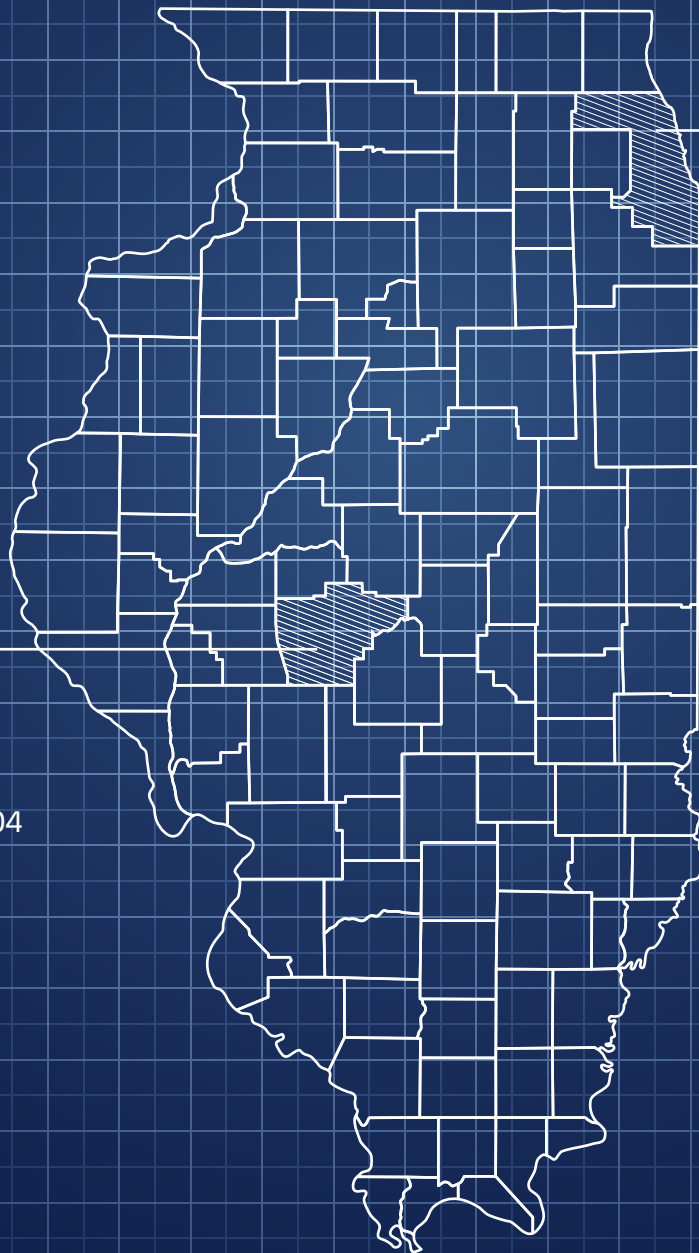

SPRINGFIELD
802 S. 2nd St.
Springfield, IL 62704

CHICAGO
300 S. Riverside Plaza
Suite 1650
Chicago, IL 60606